

FEATURES

- Rocker pin loading design
- Truck scale load cell with accessory
- Protection class IP67

SPECIFICATIONS

Max. capacity	tf	20
Rated output	mV/V	2.0 ± 0.004
Zero balance	mV/V	0 ± 0.02
Combined error	%	0.03
Repeatability	%	0.02
Creep for 30 min.	%	0.03
Temperature effect on		
Zero Value	%/10°C	0.03
Output value	%/10°C	0.015
Excitation		
Recommended	V	10
Maximum	V	15
Resistance		
Input	Ω	800 ± 40
Output	Ω	700 ± 7
Insulation	M Ω	> 2,000
Compensated temperature range	°C	-10 to +40
Operating temperature range	°C	-20 to +80

DIMENSIONS

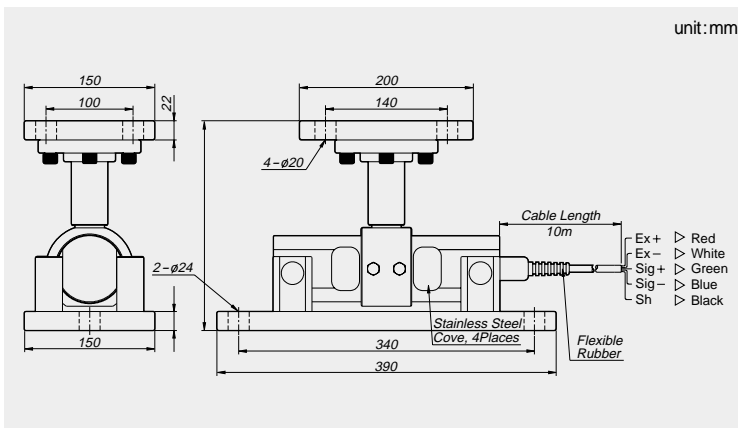

Material

Nickel plated steel

Cable

Braided shield 4-wire round cable with P.V.C-Jacket

22
240